

Model:JSMA-PBC02A3KB

No.	Item	Symbol	Unit	Specification	No.	Item	Symbol	Unit	Specification
1	Drive	-	-	3 ϕ 220VAC	13	Rotor Inertia	J-M	kg-cm ²	0.48±10%
2	Cooling Method	-	-	Totally Enclosed	14	Rated Power Rate	Q-R	Kw/s	8.53
3	Exciting Method	-	-	Permanent Magnet	15	Resistance	Ra	Ω	6.4±10%/2 ϕ
4	Resolution	-	-	23 bit-INC	16	Inductance	L	mH	16.2±10%/2 ϕ
5	Rated Output	P-R	W	200	17	Mech. Time Constant	Tm	ms	2.16±10%
6	Rated Torque	T-R	N-m	0.64	18	Elect. Time Constant	Te	ms	2.53±10%
7	Max. Torque	T-max	N-m	1.91	19	Insulation Class	-	-	Class F
8	Rated Speed	N-R	rpm	3000	20	Operation Temp.	T	°C	0~40
9	Rated Current	I-R	A	1.6	21	Operation Humd.	RH	%	<80
10	Max. Current	I-max	A	4.8	22	Storage Temp.	T	°C	-20~60°
11	Torque Constant	Kt	N-m/A	0.46	23	Storage Humd.	RH	%	<80
12	Voltage Constant	Ke	V/krpm	28±10%	24	Weight	W	kgw	1.5

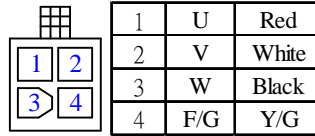

Motor Wiring

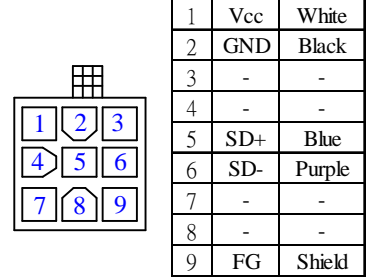

Encoder Wiring

- Note:
- 1.Motor to be IP67(excluding the shaft opening and connectors)
 - 2.Encoder shield wire to be grounded to the motor.

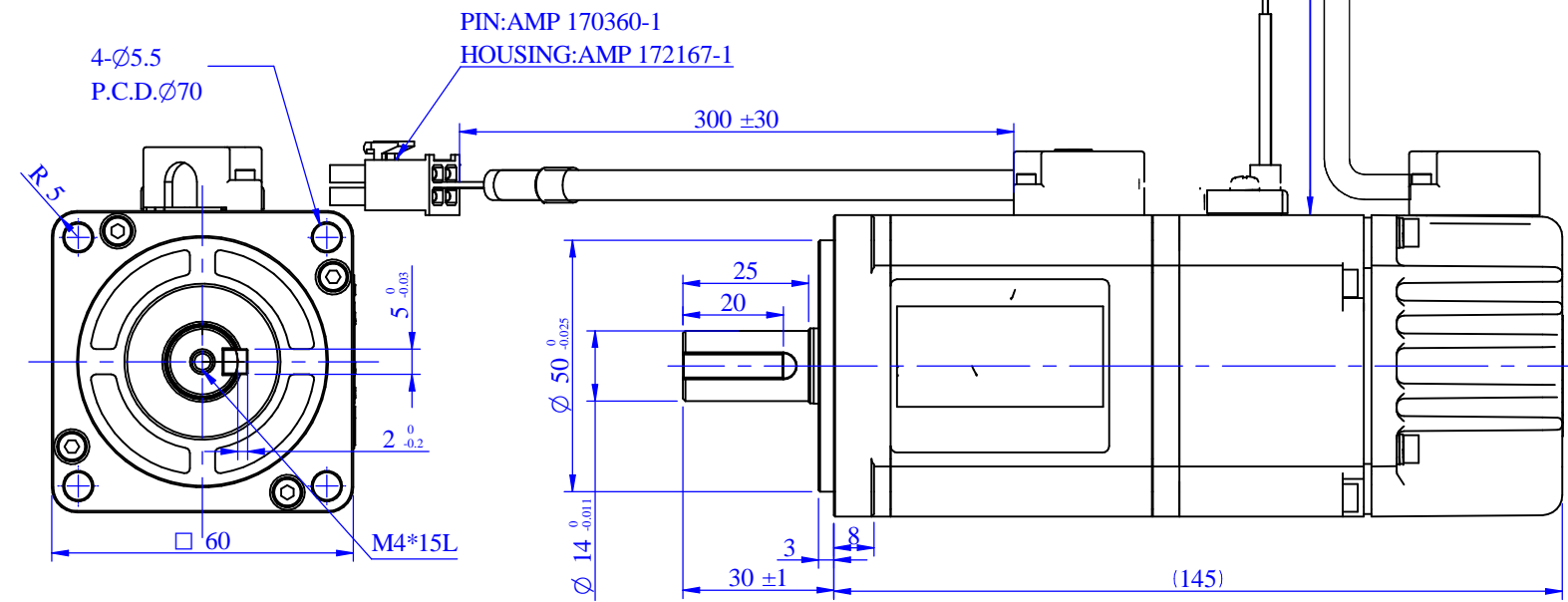

AC SERVO MOTOR

Model: JSMA-PBC02A3KB

Pr: 0.2 KW ; Nr: 3000 rpm

Ir: 1.6 A , Tr: 0.64 N-m

NO.

TECO ELECTRIC & MACHINERY CO.,LTD.

MADE IN TAIWAN

STANDARD TOLERANCE					APVD		SCALE	2/3	UNIT	m m	NAME	SERVO MOTOR OUTLINE DRAWING	
X	±0.5				CHKD						TITLE	JSMA-PBC02A3KB	
.X	±0.2				CHKD		3RD .A.P						
.XX	±0.05				DWN	Leon							
ANGLE	±30'					04-08-'16							
MATERIAL		REV	DESCRIPTION	SIGNATURE	DATE	SIGNATURE	DATE	TECO ELECTRO DEVICES CO., LTD.		Dept. Design	DWG.NO.	D01E06201C3BZ3D01	